

AX58100 Product Introduction

Revision 1.02
Jan. 27th, 2022

Revision History

Revision	Date	Description
0.10	2018/06/12	Preliminary release
1.00	2018/09/27	1. Modified some descriptions in Section 1, 3.
1.01	2018/11/23	1. Added Ordering Information in Section 4. 2. Added AX58100 evaluation boards information in Figure 1 & 2
1.02	2022/01/27	Corrected top of page description.

Table of Contents

1. Introduction	4
2. Block Diagram	6
3. Major Features	6
4. Ordering Information	7
5. Target Applications.....	8
6. AX58100 Evaluation Board.....	9
6-1. AX58100 Evaluation Board	9
7. AX58100 Demo Kits	10
7-1. AX58100 SPI Master ADC Sensor/DIO Demo Kit	10
7-2. AX58100 Six-Step PWM BLDC Motor Control with SPI Slave MCU CoE F/W Demo Kit Demo Kit.....	11
7-3. AX58100 + AX99100 Local Bus Demo Kit	12
8. Hardware/Software Support.....	13

List of Figures

Figure 1. AX58100 Evaluation Board for Copper Application	5
Figure 2. AX58100 Evaluation Board for Fiber Application	5
Figure 3. AX58100 Block Diagram	6
Figure 4. AX58100 Major Features.....	6
Figure 5. Ordering Information	7
Figure 6. AX58100 Target Applications	8
Figure 7. AX58100 Evaluation Board	9
Figure 8. AX58100 Evaluation Board Jumpers Setting.....	9
Figure 9. AX58100 SPI Master ADC Sensor/DIO Demo Kit & TwinCAT PLC Demo	10
Figure 10. AX58100 SPI Master ADC Sensor/DIO Demo Kit Block Diagram	10
Figure 11. AX58100 Six-Step PWM BLDC Motor Control Demo Kit & TwinCAT PLC Demo	11
Figure 12. AX58100 Six-Step PWM BLDC Motor Control Demo Kit Block Diagram	11
Figure 13. AX58100 + AX99100 Local Bus Demo Kit & Windows SSC/TwinCAT PLC Demo.....	12
Figure 14. AX58100 + AX99100 Local Bus Demo Kit Block Diagram	12

1. Introduction

This document provides an overview of [AX58100 2/3-port EtherCAT slave controller](#).

The AX58100 is a 2/3-port EtherCAT Slave Controller (ESC), licensed from Beckhoff Automation, with two integrated Fast Ethernet PHYs which support 100Mbps full-duplex operation and HP Auto-MDIX. The AX58100 is interoperable with all EtherCAT systems with standard EtherCAT protocols such as CANopen over EtherCAT (CoE), File Access over EtherCAT (FoE), Vendor Specific-protocol over EtherCAT (VoE), etc. The AX58100 provides a cost-effective EtherCAT solution for industrial automation, motion/motor/Digital IO control, Digital to Analog (DAC)/Analog to Digital (ADC) converters control, sensors data acquisition, robotics, etc. industrial fieldbus applications.

The AX58100 provides either a three-channel PWM controller or a Step/Direction controller, and an Incremental (ABZ)/Hall Encoder interface for closed-loop motion/motor control applications; provides a SPI master controller for Digital to Analog (DAC)/Analog to Digital (ADC) converters control applications and sensors data acquisition applications; provides 32 Digital I/Os (DIO) for industrial fieldbus I/O control applications; and also provides an I/O watchdog and an emergency stop input for industrial automation functional safety applications.

The AX58100 provides SPI slave and Local bus Process Data Interfaces (PDI) to provide an easy way for system designers to implement the standard EtherCAT communication functionalities on those traditional non-EtherCAT MCU and DSP industrial platforms. AX58100 supports a configurable individual function SPI slave interface to enhance SPI slave bandwidth.

To help customers to evaluate and develop applications with AX58100 EtherCAT slave controller, ASIX provides comprehensive technical support including reference schematics, PCB design guidelines, hardware/software application notes, user guides, software firmware, etc., and also provides AX58100 evaluation board for designers to easily evaluate the AX58100 EtherCAT slave controller functionalities.

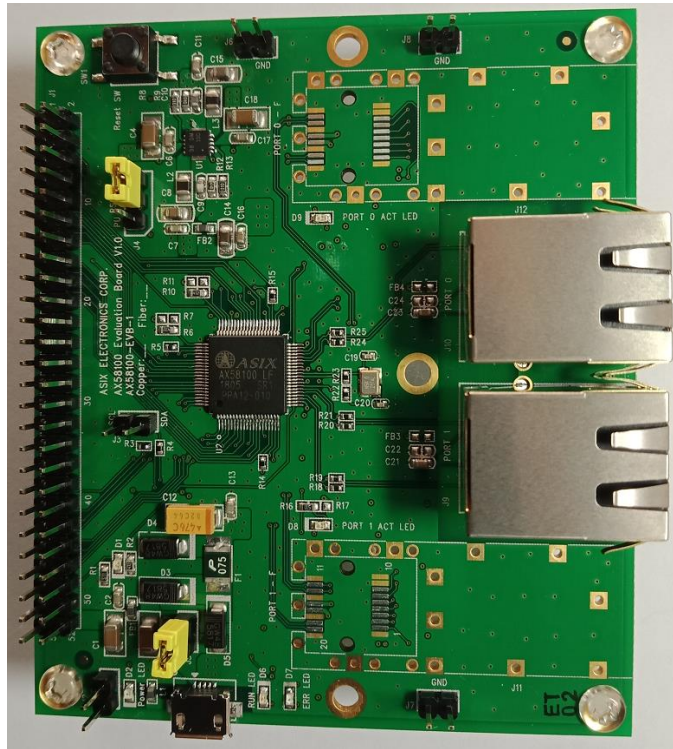

Figure 1. AX58100 Evaluation Board for Copper Application



Figure 2. AX58100 Evaluation Board for Fiber Application

2. Block Diagram

The following is AX58100 block diagram,

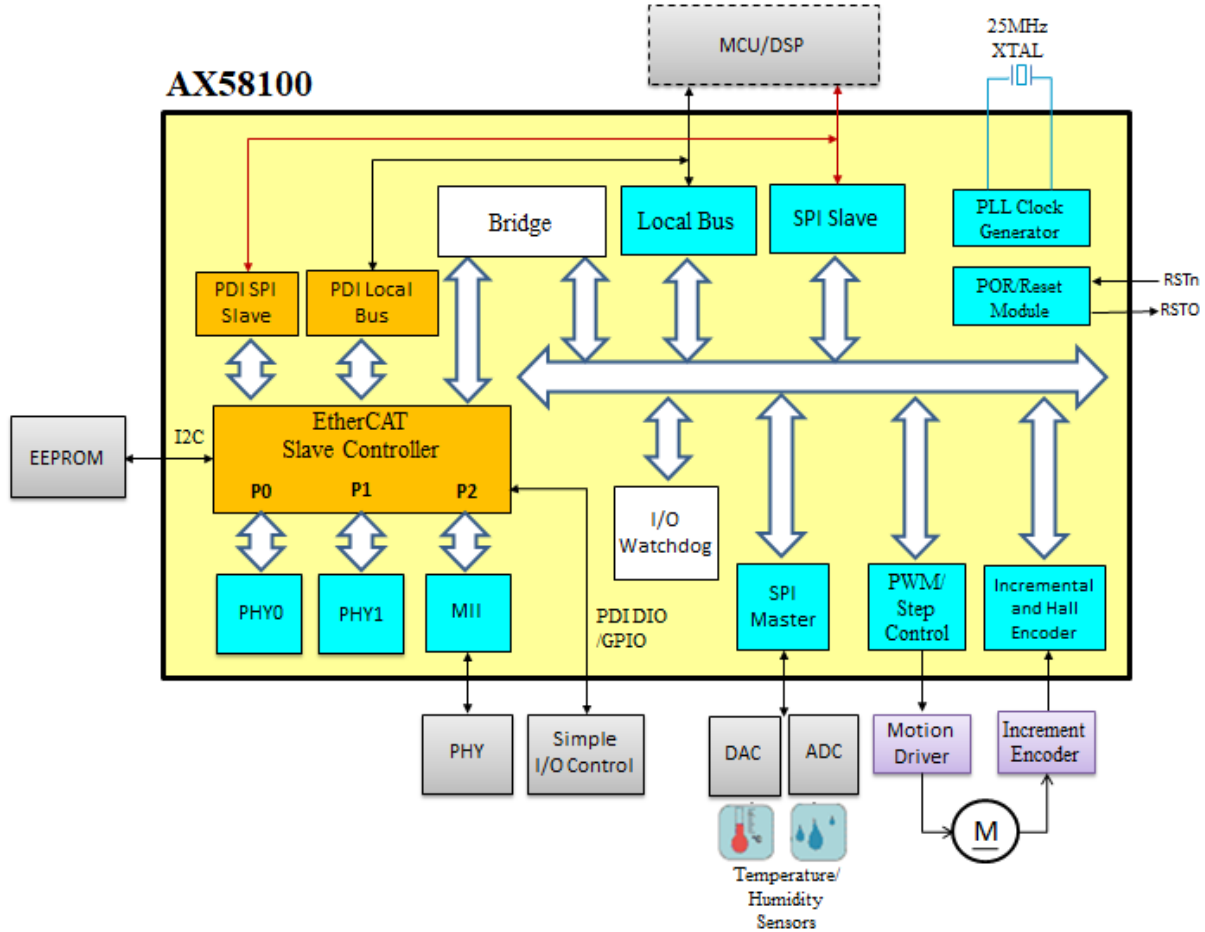

Figure 3. AX58100 Block Diagram

3. Major Features

The following are AX58100 major features,

Fast Ethernet Ports	FMMU	Sync Managers	RAM (Kbytes)	Distributed Clock	Digital I/O	SPI Slave
2 x Internal PHY 1 x MII	8	8	9	64-bit	32-bit	Yes
Local Bus	SPI Master	PWM	Incremental (ABZ)/ Hall Encoder	Emergency Stop Input	Temperature Range (°C)	Package
8/16-bit Async	Yes	Yes	Yes	Yes	-40 ~ +105	LQFP-80

Figure 4. AX58100 Major Features

4. Ordering Information

The following is the ordering information of AX58100 and the evaluation boards. Please contact ASIX's Sales (sales@asix.com.tw) for details.

Part Number	Description
AX58100 LT	80-pin LQFP Lead Free package, Industrial temperature range: -40 to 105°C.

AX58100 Evaluation Boards	Description
AX58100-EVB-1 (Copper)	This is an EtherCAT Slave Controller Evaluation Board for AX58100 Copper application
AX58100-EVB-1 (Fiber)	This is an EtherCAT Slave Controller Evaluation Board for AX58100 Fiber application

Figure 5. Ordering Information

5. Target Applications

The following are AX58100 typical target applications.

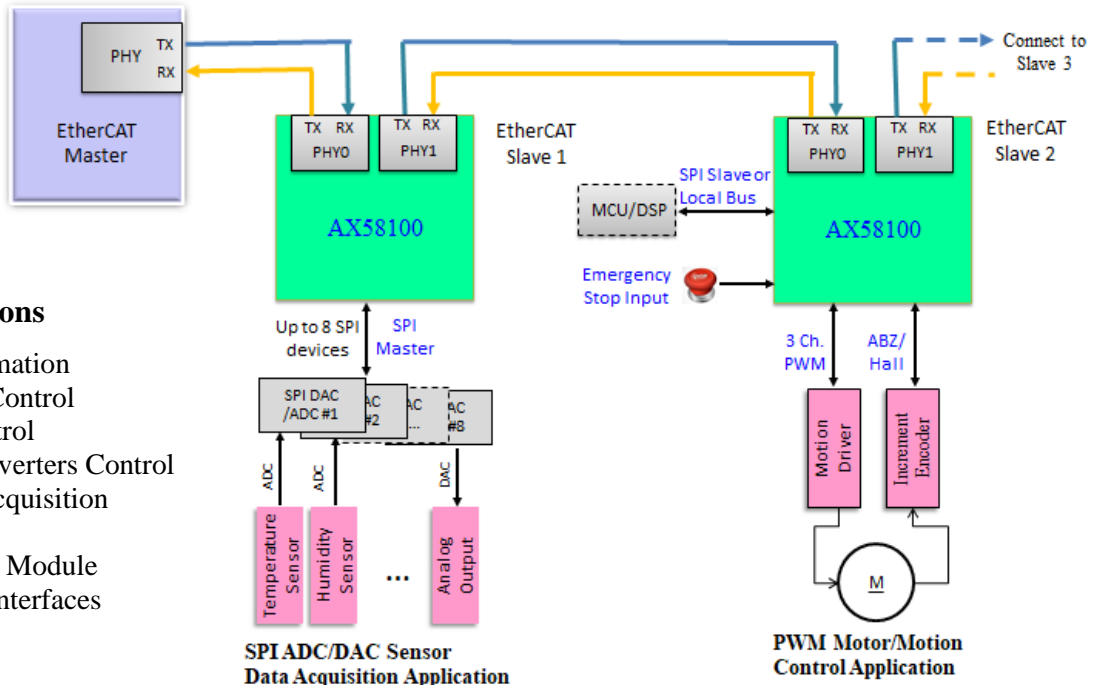

Target Applications

- Industrial Automation
- Motor/Motion Control
- Digital I/O Control
- DAC/ADC Converters Control
- Sensors Data Acquisition
- Robotics
- Communication Module
- Operator HMI Interfaces

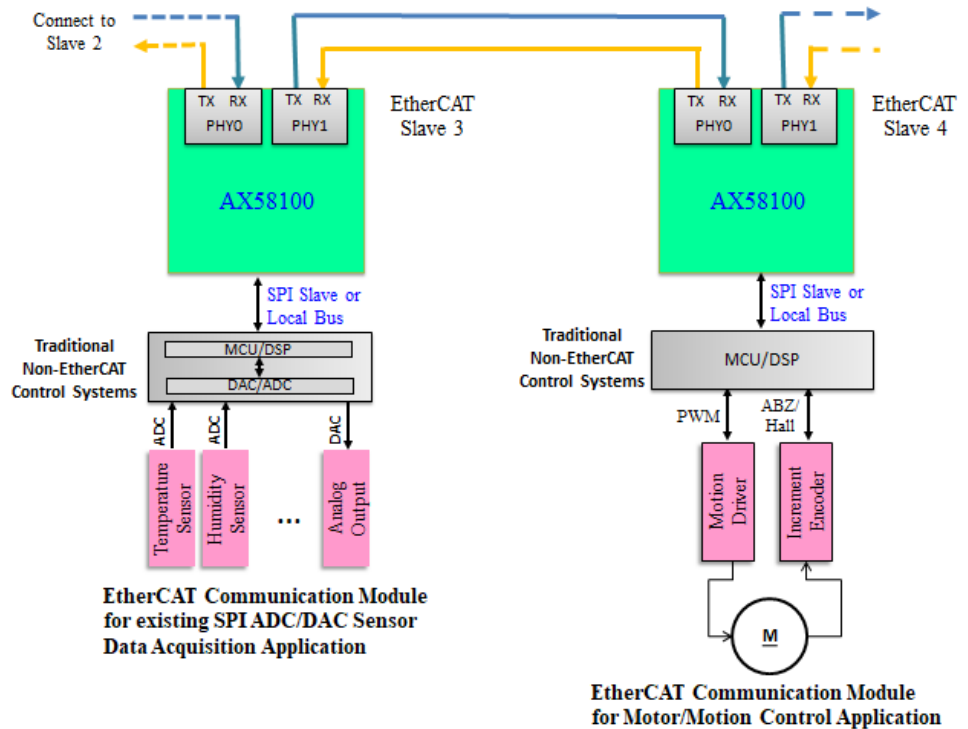

Figure 6. AX58100 Target Applications

6. AX58100 Evaluation Board

ASIX Electronics provides AX58100 Evaluation Board for users to evaluate AX58100 functionalities on different target applications.

6-1. AX58100 Evaluation Board

Interface Connector

		J1			
GND	1	1	2	GND	
RSTO	3	3	4	RSTn_I	
GPIO00	5	5	6	GPIO01	
GPIO02	7	7	8	GPIO03	
GPIO04	9	9	10	GPIO05	
GPIO06	11	11	12	GPIO07	
GPIO08	13	13	14	GPIO09	
GPIO10	15	15	16	GPIO11	
GPIO12	17	17	18	GPIO13	
GPIO14	19	19	20	GPIO15	
GND	21	21	22	GND	
GPIO16	23	23	24	GPIO17	
GPIO18	25	25	26	GPIO19	
GPIO20	27	27	28	GPIO21	
GPIO22	29	29	30	GPIO23	
GPIO24	31	31	32	GPIO25	
GPIO26	33	33	34	GPIO27	
GPIO28	35	35	36	GPIO29	
GPIO30	37	37	38	GPIO31	
OE_EXT	39	39	40	GND	
OUTVLD	41	41	42	SOFT	
EOF	43	43	44	WD_TRIG	
SYNC_L0	45	45	46	SYNC_L1	
LAT_IN	47	47	48	EOP_DONE	
GND	49	49	50	GND	
DB_5V	51	51	52	DB_5V	

CON52A_2X26_2.54mm

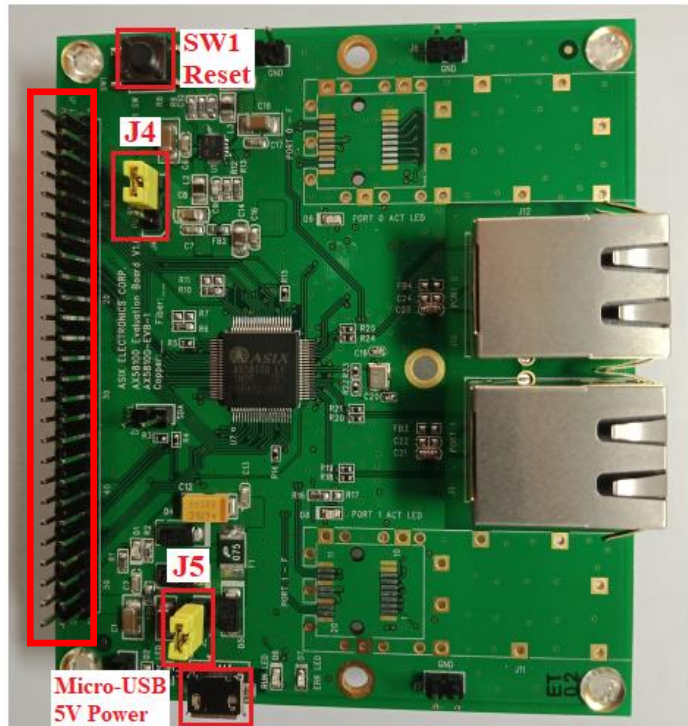

Figure 7. AX58100 Evaluation Board

The following is the jumper setting table of the AX58100 Evaluation Board.

Jumper	Setting	Description
J4	J4 <input checked="" type="checkbox"/> 123	Pull-up AX58100 RSTO signal
	J4 <input type="checkbox"/> 123 (Default)	Pull-down AX58100 RSTO signal
J5	J5 <input checked="" type="checkbox"/>	Provide separate 5V power supply to the interface connector J1 (DB_5V)
	J5 <input type="checkbox"/> (Default)	Provide 5V power supply from Micro-USB 5V power connector to the interface connector J1 (DB_5V)

Figure 8. AX58100 Evaluation Board Jumpers Setting

7. AX58100 Demo Kits

ASIX Electronics provides different AX58100 applications demo kits which include AX58100 reference schematic, BOM/PCB layout/gerber files, TwinCAT PLC demo source, sample ESI file, etc. Designers can refer to these AX58100 technical archives to easily evaluate and implement AX58100 on different EtherCAT target applications.

7-1. AX58100 SPI Master ADC Sensor/DIO Demo Kit

The AX58100 SPI Master ADC Sensor/DIO Demo Kit demonstrates AX58100 SPI Master and Digital I/O functionalities for the ADC sensor data acquisition and digital I/O control target applications.

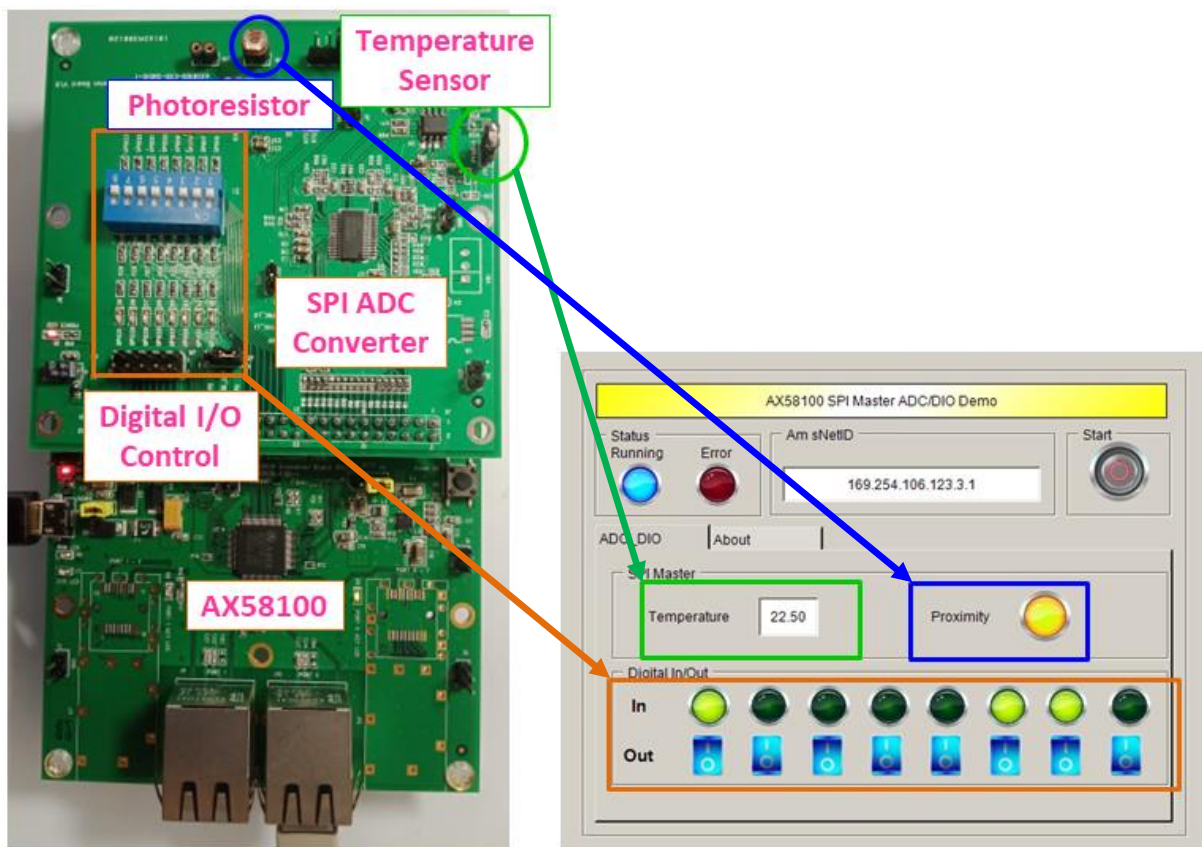

Figure 9. AX58100 SPI Master ADC Sensor/DIO Demo Kit & TwinCAT PLC Demo

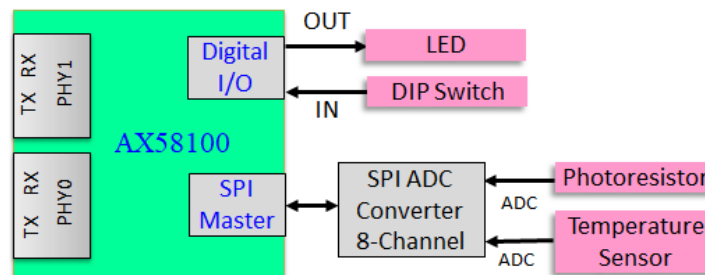

Figure 10. AX58100 SPI Master ADC Sensor/DIO Demo Kit Block Diagram

7-2. AX58100 Six-Step PWM BLDC Motor Control with SPI Slave MCU CoE F/W Demo Kit Demo Kit

The AX58100 Six-Step PWM BLDC Motor Control Demo Kit demonstrates the AX58100 PWM/Hall Encoder and SPI slave PDI functionalities for the PWM motor/motion control target applications.

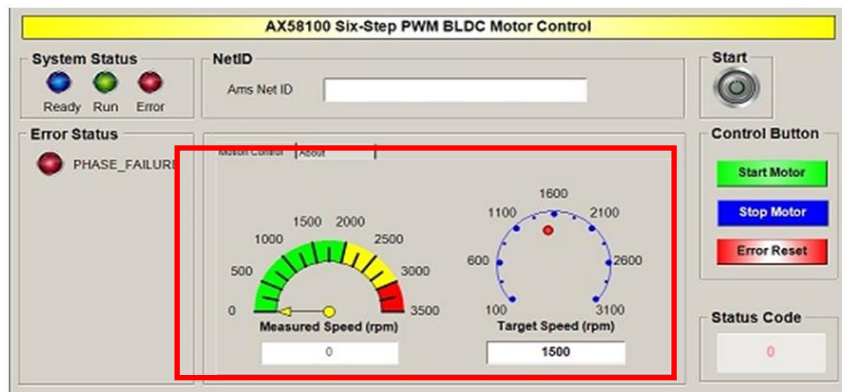
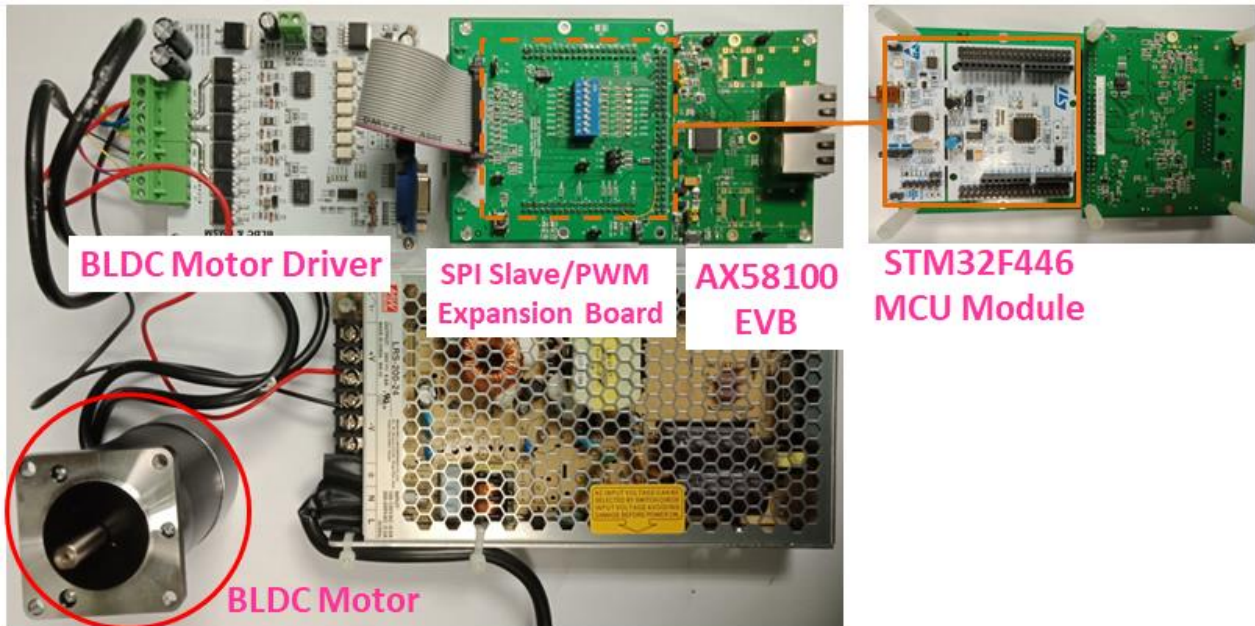

Figure 11. AX58100 Six-Step PWM BLDC Motor Control Demo Kit & TwinCAT PLC Demo

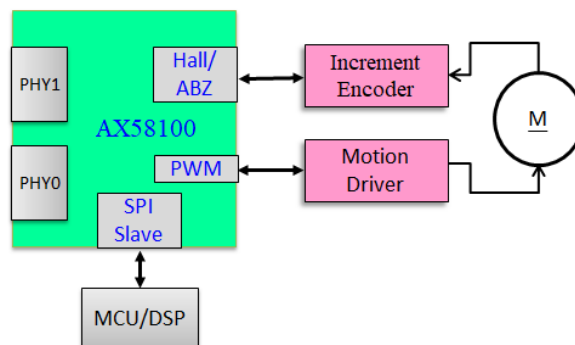

Figure 12. AX58100 Six-Step PWM BLDC Motor Control Demo Kit Block Diagram

7-3. AX58100 + AX99100 Local Bus Demo Kit

The AX58100 + AX99100 Local Bus Demo Kit demonstrates the AX58100 Local Bus PDI functionalities for the PCIe EtherCAT slave adapter applications.

AX58100 TwinCAT PLC Demo



AX58100 Windows SSC Demo

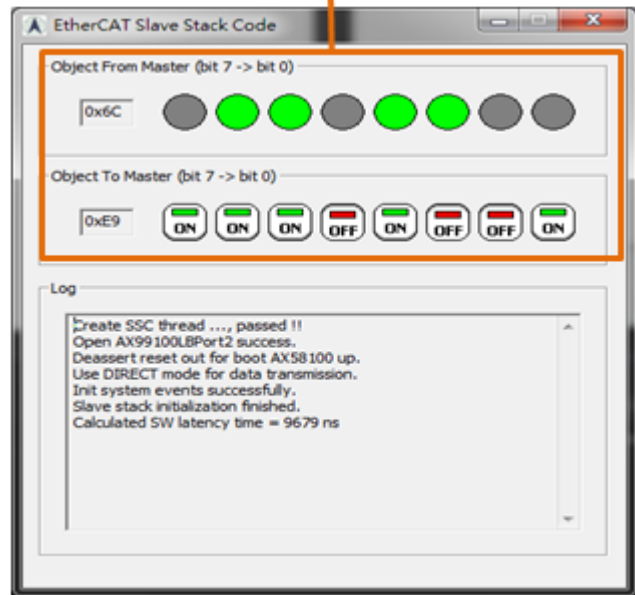

Figure 13. AX58100 + AX99100 Local Bus Demo Kit & Windows SSC/TwinCAT PLC Demo

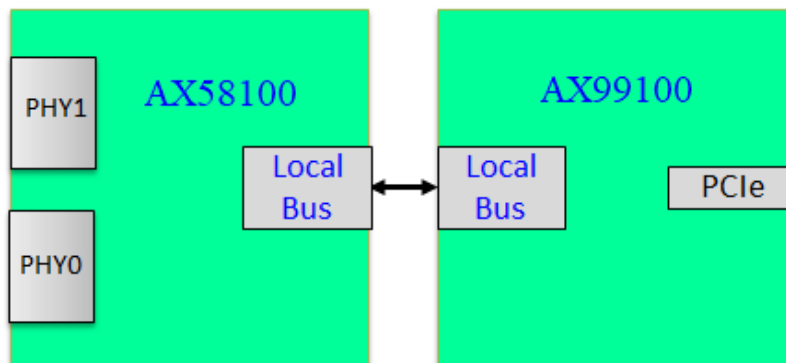

Figure 14. AX58100 + AX99100 Local Bus Demo Kit Block Diagram

8. Hardware/Software Support

AX58100 supports different applications demo kits described in [Section 7](#) which include AX58100 evaluation board reference schematic, PCB layout/gerber/BOM files, application design note and sample TwinCAT PLC demo source/ESI file, etc. Please contact ASIX Sales (Sales@asix.com.tw) for details.



**4F, No.8, Hsin Ann Rd., Hsinchu Science Park,
Hsinchu, Taiwan, R.O.C.**

TEL: +886-3-5799500

FAX: +886-3-5799558

Email: support@asix.com.tw

Web: <http://www.asix.com.tw>