



**ZSP4403**  
**Low Voltage Electroluminescent Lamp Driver**  
**High Voltage Output for Large Display**  
**Datasheet**

Revision 2.01  
May 29<sup>th</sup>, 2019





**IMPORTANT NOTICE**

Copyright © 2005-2015 ASIX Electronics Corporation. All rights reserved.

**DISCLAIMER**

No part of this document may be reproduced or transmitted in any form or by any means, electronic or mechanical, including photocopying and recording, for any purpose, without the express written permission of ASIX. ASIX may make changes to the product specifications and descriptions in this document at any time, without notice.

ASIX provides this document “as is” without warranty of any kind, either expressed or implied, including without limitation warranties of merchantability, fitness for a particular purpose, and non-infringement.

Designers must not rely on the absence or characteristics of any features or registers marked “reserved”, “undefined” or “NC”. ASIX reserves these for future definition and shall have no responsibility whatsoever for conflicts or incompatibilities arising from future changes to them. Always contact ASIX to get the latest document before starting a design of ASIX products.

**TRADEMARKS**

ASIX, the ASIX logo are registered trademarks of ASIX Electronics Corporation. All other trademarks are the property of their respective owners.

### Features

- High-efficiency design
- +2.2V to +5.0V battery operation
- DC-to-AC converter produces typical 195Vpp signals for EL display panels
- Single resistor controlled internal oscillator
- Low current standby mode draws less than 1 $\mu$ A
- Uses small 470 $\mu$ H, Sub 2mm height coil

### Applications

- PDA's, MP3 Players
- 
- 
- 
- 

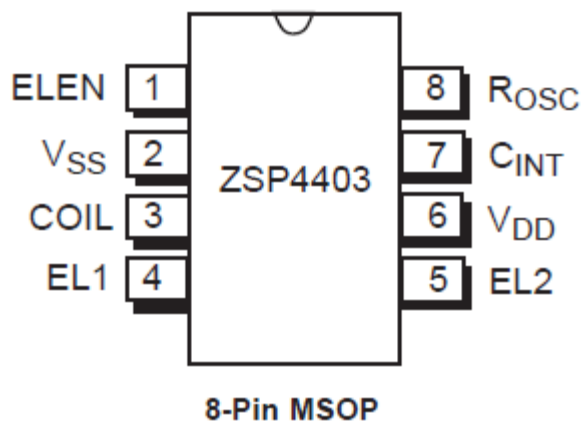

### General Description

The ZSP4403 is a high voltage output DC-AC inverter specifically designed to drive electroluminescent lamps to backlight liquid crystal displays, keypads, and backlit readouts used in battery operated portable equipment. The ZSP4403 is designed with our proprietary high voltage BiCMOS technology. The ZSP4403 will operate from a +2.2V to +5.0V battery source. The device features a low power shutdown mode which draws less than 100nA (typical), ideal for low power portable products. One external inductor is required to generate the high voltage AC output. One external resistor is used to select the internal oscillator frequency. The ZSP4403 is ideal for portable applications such as PDA's, pagers, cellular phones, and other portable applications using LCDs in dim or low light environments. The ZSP4403 is offered in 8-pin MSOP packages.



**Absolute Maximum Ratings**

These are stress ratings only and functional operation of the device at these ratings or any other above those indicated in the operation sections of the specifications is not implied. Exposure to absolute maximum rating conditions for extended periods of time may affect reliability.

Power Supply, (V <sub>BATT</sub> ).....	+7.0V
Input Voltages, ELEN (pin 1) .....	-0.5V to (V <sub>DD</sub> +0.5V)
Lamp Outputs.....	230V <sub>pp</sub>
Operating Temperature.....	-40°C to +85°C
Storage Temperature.....	-65°C to +150°C

**Power Dissipation Per Package**

8-pin MSOP (derate 4.85mW/°C above +70°C) .....400mW

**Storage Considerations**

Storage in a low humidity environment is preferred. Large high density plastic packages are moisture sensitive and should be stored in Dry Vapor Barrier Bags. Prior to usage, the parts should remain bagged and stored below 40°C and 60%RH. If the parts are removed from the bag, they should be used within 168 hours or stored in an environment at or below 20%RH. If the above conditions cannot be followed, the parts should be baked for 12 hours at 125°C in order to remove moisture prior to soldering. ASIX ships product in Dry Vapor Barrier Bags with a humidity indicator card and desiccant pack. The humidity indicator should be below 30%RH. The MSL of this product is 3.

The information furnished by ASIX has been carefully reviewed for accuracy and reliability. Its application or use, however, is solely the responsibility of the user. No responsibility of the use of this information become part of the terms and conditions of any subsequent sales agreement with ASIX. Specifications are subject to change without the responsibility for any infringement of patents or other rights of third parties which may result from its use. No license or proprietary rights are granted by implication or otherwise under any patent or patent rights of ASIX Electronics Corporation.





# 1 Electrical Characteristics

V<sub>BATT</sub> = +3.0V, L<sub>1</sub> = 470μH/12Ω, R<sub>OSC</sub> = 450KΩ, CLAMP = 15nF/35nF, C<sub>INT</sub> = 680pF, C<sub>1</sub> = 1.0μF, and C<sub>2</sub> = 10nF;  
T<sub>A</sub> = +25°C, unless otherwise noted.

Symbol	Parameter	Condition	Min	Typ	Max	Units
V <sub>DD</sub>	Supply Voltage		2.2	3.0	5.0	V
I <sub>DD</sub>	Supply Current	V <sub>DD</sub> = V <sub>COIL</sub> = +3.0V		1.5	3.0	mA
		V <sub>DD</sub> = V <sub>COIL</sub> = +5.0V		3.8	6.0	mA
I <sub>COIL</sub> + I <sub>DD</sub>	Supply Current	V <sub>DD</sub> = V <sub>COIL</sub> = +3.0V		45	65	mA
		V <sub>DD</sub> = V <sub>COIL</sub> = +5.0V		65	95	mA
V <sub>COIL</sub>	Coil Voltage		V <sub>DD</sub>		5.0	V
V <sub>ELEN</sub>	ELEN Input Voltage		-0.25	0	0.25	V
	LOW: EL off	V <sub>DD</sub> = +2.8V to +5.0V	V <sub>DD</sub> *0.61	V <sub>DD</sub>	V <sub>DD</sub> +0.25	V
	HIGH: EL on	V <sub>DD</sub> = +2.2V to +2.8V	1.7	V <sub>DD</sub>	V <sub>DD</sub> +0.25	V
I <sub>SD</sub> = I <sub>COIL</sub> + I <sub>DD</sub>	Shutdown Current	V <sub>DD</sub> = V <sub>COIL</sub> = +5.0V		0.05	1.0	uA
<b>INDUCTOR DRIVE</b>						
f <sub>COIL</sub>	Coil Frequency			50		KHz
	Coil Duty Cycle			90		%
I <sub>PK-COIL</sub>	Peak Coil Current	Guaranteed by design			85	mA
<b>EL LAMP OUTPUT</b>						
f <sub>LAMP</sub>	EL Lamp Frequency	V <sub>DD</sub> = V <sub>COIL</sub> = +3.0V	300	400		Hz
V <sub>PP</sub>	Peak-to-Peak Output Voltage	V <sub>DD</sub> = V <sub>COIL</sub> = +3.0V, CLAMP = 15nF	170	195		V
		V <sub>DD</sub> = V <sub>COIL</sub> = +5.0V, CLAMP = 35nF	170	200		V

## 2 Block Diagram

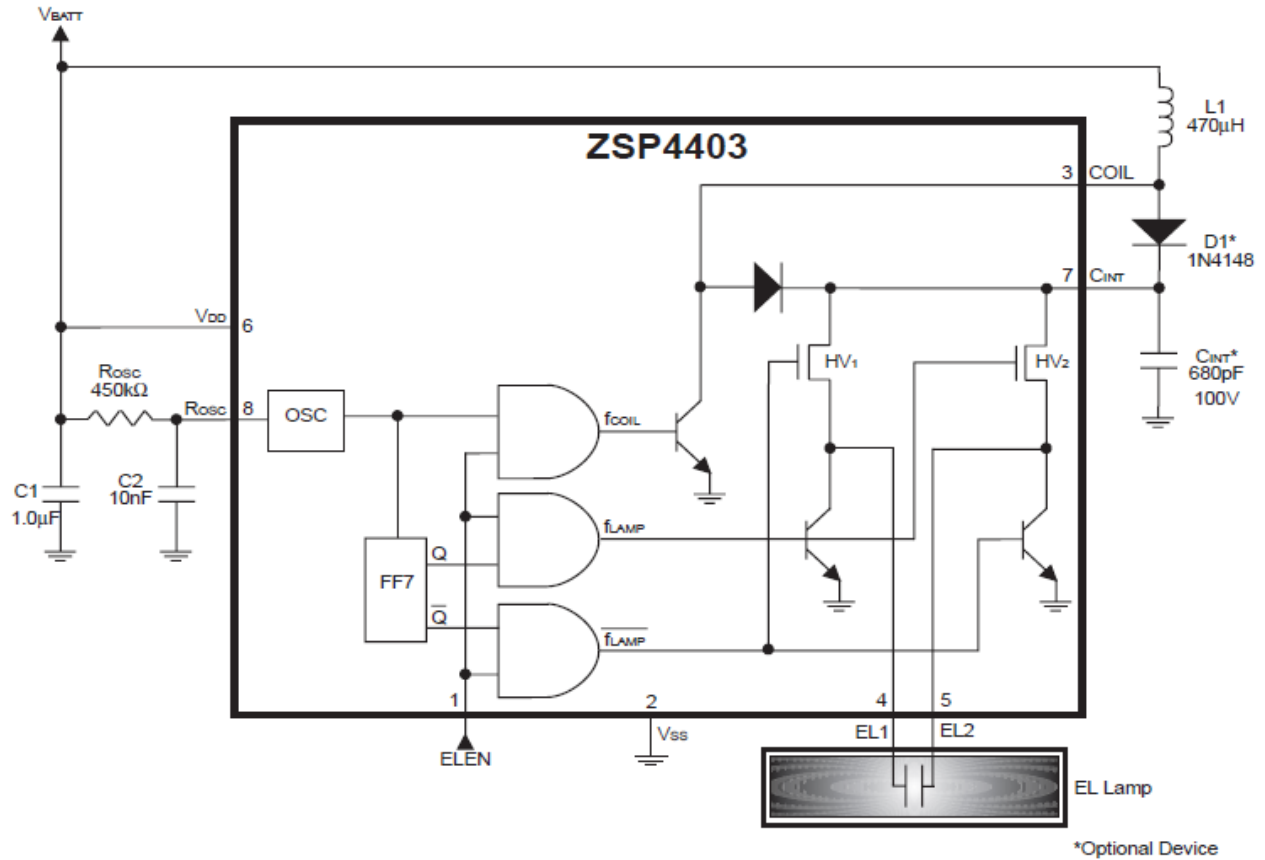

Figure 1. ZSP4403 Block Diagram

### 3 Pin Description

Pin Number	Pin Name	Pin Description
1	ELEN	Electroluminescent Lamp Enable. When driven HIGH, this input pin enables the EL driver output EL1 and EL2 (pins 4 and 5, respectively) to the EL lamp ( <a href="#">Note_1</a> )
2	V <sub>SS</sub>	Power Supply Common. Connect to the lowest circuit potential, typically ground.
3	COIL	Coil. The inductor for the EL lamp is connected from V <sub>BATT</sub> to this input pin.
4	EL1	Electroluminescent Lamp Output 1. This is a lamp driver output pin to connect to the EL lamp.
5	EL2	Electroluminescent Lamp Output 2. This is a lamp driver output pin to connect to the EL lamp.
6	V <sub>DD</sub>	Positive Battery Power Supply. Connect such that $+2.2V < V_{DD} < +5.0V$ .
7	C <sub>INT</sub>	Integrating Capacitor. Connecting a fast recovery diode from COIL (pin 3) to this input pin increases the light output of the EL lamp. By connecting a capacitor (0.1 $\mu$ F) from this pin to ground, the designer can alter the sawtooth wave output at EL1 and EL2 (pins 4 and 5, respectively) to a square wave output.
8	R <sub>OSC</sub>	Oscillator Resistor. Connecting a 450K $\Omega$ resistor to this input pin sets the frequency of the internal clock.

**Note\_1:** This pin cannot put any high loading. It will cause output waveform distortion.

### 4 Pin Configuration

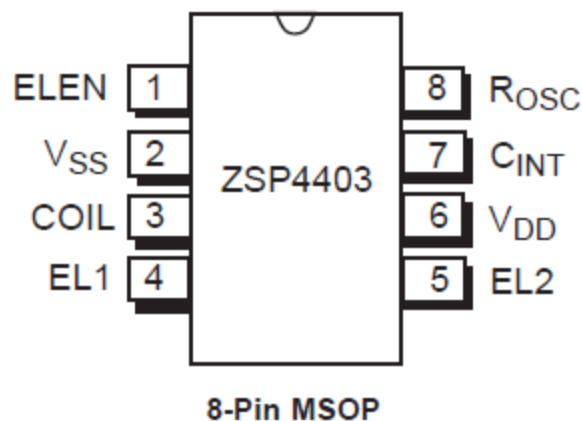

## 5 Circuit Description

The ZSP4403 contains a DC-AC inverter that can produce up to 230V<sub>PP</sub> AC output from a +2.2V to +5.0V input voltage. An internal block diagram of the ZSP4403 can be found in *Figure 1*.

The ZSP4403 is built on ASIX's proprietary high voltage BiCMOS process that provides the isolation required to separate the high voltage AC signal used to drive the EL lamp from the low voltage logic and signal processing circuitry. This ensures latch-up free operation in the interface between the low voltage CMOS circuitry and the high voltage bipolar circuitry. The ZSP4403 is ideal for applications driving EL lamps to backlight LCD displays, key panels, and other backlit readouts used in battery operated portable equipment. A total of six external components are typically used in standard operation of the ZSP4403: an inductor, a fast recovery diode, three capacitors and a resistor. A diagram of the ZSP4403 in a typical application can be found in *Figure 2*.

### Electroluminescent Technology

An EL lamp is basically a strip of plastic that is coated with a phosphorous material which emits light (fluoresces) when a high voltage (>40V) which was first applied across it, is removed or reversed. Long periods of DC voltages applied to the material tend to breakdown the material and reduce its lifetime. With these considerations in mind, the ideal signal to drive an EL lamp is a high voltage sine wave. Traditional approaches to achieving this type of waveform included discrete circuits incorporating a transformer, transistors, and several resistors and capacitors. This approach is large and bulky, and cannot be implemented in most hand held equipment. ASIX offers low power single chip driver circuits specifically designed to drive small to medium sized electroluminescent panels.

### Market Applications

Electroluminescent backlighting is ideal when used with LCD displays, keypads, or other backlit readouts. Its main use is to illuminate displays in dim to dark conditions for momentary periods of time. EL lamps consume less power than LEDs or incandescent bulbs making them ideal for battery powered products. Also, EL lamps are able to uniformly light an area without creating any undesirable "hot spots" in the display.



## 6 Theory of Operation

The ZSP4403 is a DC-AC inverter made up of:

1. The Oscillator/Frequency Divider,
2. The Coil, and
3. The Switched H-bridge Network.

Further details of each element follow.

### The Oscillator/Frequency Divider

The oscillator provides the ZSP4403 with an on-chip clock used to control the coil switch ( $f_{COIL}$ ) and the H-bridge network ( $f_{LAMP}$  and  $f_{LAMP}$ ). Although the oscillator frequency can be varied to optimize the lamp output, the ratio of ( $f_{COIL}/f_{LAMP}$ ) will always equal 128. *Figure 1* shows the oscillator output driving the coil and the output of the oscillator with 7 flip flops driving the lamp. The suggested oscillator frequency is 50KHz ( $R_{OSC} = 450K\Omega$ ) for  $f_{COIL}$ . The oscillator output is internally divided down by 7 flipflops to create a second internal control signal at 390Hz for  $f_{LAMP}$ .

### The Coil

The supply  $V_{BATT}$  can range from +2.2V to +5.0V.  $V_{BATT}$  should not exceed the maximum coil current specification. The majority of the current goes through the coil and is typically much greater than  $I_{DD}$ . The coil is an external component connected from  $V_{BATT}$  to pin 3 of the ZSP4403. Energy is stored in the coil according to the equation  $E_L = 1/2(LI_P)^2$  where  $I_P$ , to the first approximation, is the product  $I_P = (t_{ON})((V_{BATT} - V_{CE})/L)$ , where  $t_{ON}$  is the time it takes for the coil to reach its peak current,  $V_{CE}$  is the voltage drop across the internal NPN switch transistor, and  $L$  is the inductance of the coil. When the NPN transistor switch is off, the energy is forced through an internal diode which drives the switched H-bridge network. This energy recovery is directly related to the brightness of the EL lamp output. There are many variations among coils; magnetic material differences, winding differences and parasitic capacitances. For suggested coil suppliers, refer to "Coil Manufacturers." The  $f_{COIL}$  signal controls a switch that connects the end of the coil at pin 3 to ground or to open circuit. The  $f_{COIL}$  signal is a 90% duty cycle signal switching at the oscillator frequency, 50KHz. During the time when the  $f_{COIL}$  signal is HIGH, the coil is connected from  $V_{BATT}$  to ground and a charged magnetic field is created in the coil. When the  $f_{COIL}$  signal is LOW, the ground connection is switched open, the field collapses, and the energy in the inductor is forced to flow toward the high voltage H-bridge switches.  $f_{COIL}$  will send an array of charge pulses (see *Figure 4*) to the lamp. Each pulse increases the voltage drop across the lamp in discrete steps. As the voltage potential approaches its maximum, the steps become smaller (see *Figure 3*)

### The Switched H-Bridge Network

The H-bridge consists of two proprietary low on resistance high voltage switches. These two switches control the polarity of how the lamp is charged. The high voltage switches are controlled by the  $f_{LAMP}$  signal which is the oscillator frequency divided by 128. For a 50KHz oscillator, the 7 flip flops will drive  $f_{LAMP} = 390\text{Hz}$ .

The direction of current flow is determined by which high voltage is enabled. One full cycle of the H-bridge will create 128 voltage steps from ground to 80V (typical) on EL1 and EL2 (pins 4 and 5, respectively) which are 180 degrees out of phase from each other (see *Figure 5*). A differential representation of the output is shown in *Figure 6*.

### **Fine Tuning Performance**

Circuit performance of the ZSP4403 can be improved with some of the following suggestions:

#### **Increase EL Lamp Light Output**

By connecting a fast recovery diode from COIL (pin 3) to CINT (pin 7), the internal diode of the switched H-bridge network is bypassed resulting in an increase in light output at the EL lamp. We suggest a fast recovery diode, such as the industry standard 1N4148, be used for D1. This circuit connection can be found in *Figure 2*.

#### **Square Wave Output Waveform to the EL Lamp**

A 680pF capacitor at CINT (pin 7) will act as an integrating capacitor, filtering out any coil switching spikes or ripple in the output waveform to the EL lamp (shown in *Figure 1*). A designer may change the output waveform to a square wave by using a 0.1uF capacitor (shown in *Figure 2*) at CINT (pin 7).

#### **Printed Circuit Board Layout Suggestions**

The ZSP4403's high-frequency operation makes PC layout important for minimizing ground bounce and noise. Keep the ICs GND pin and the ground leads of C1 and CINT in *Figure 2* less than 0.2 in (5mm) apart. Also keep the connections to L1 (pin 3) as short as possible. To maximize output power and efficiency and minimize output ripple voltage, use a ground plane and solder the ICs VSS (pin 2) directly to the ground plane.

#### **EL Lamp Driver Design Challenges**

There are many variables which can be optimized for specific applications. The amount of light emitted is a function of the voltage applied to the lamp, the frequency at which it is applied, the lamp material, the lamp size, and the inductor used. ASIX will perform customer application evaluations, using the customer's actual EL lamp to determine the optimum operating conditions for specific applications. For customers considering an EL backlighting solution for the first time, ASIX is able to offer retrofitted solutions to the customer's existing LED or non-backlit product for a thorough electrical and cosmetic evaluation. Please contact your local sales representative for ASIX or the ASIX factory directly to initiate this valued service.

## 7 Typical Application

Contact the factory for any technical or application support.

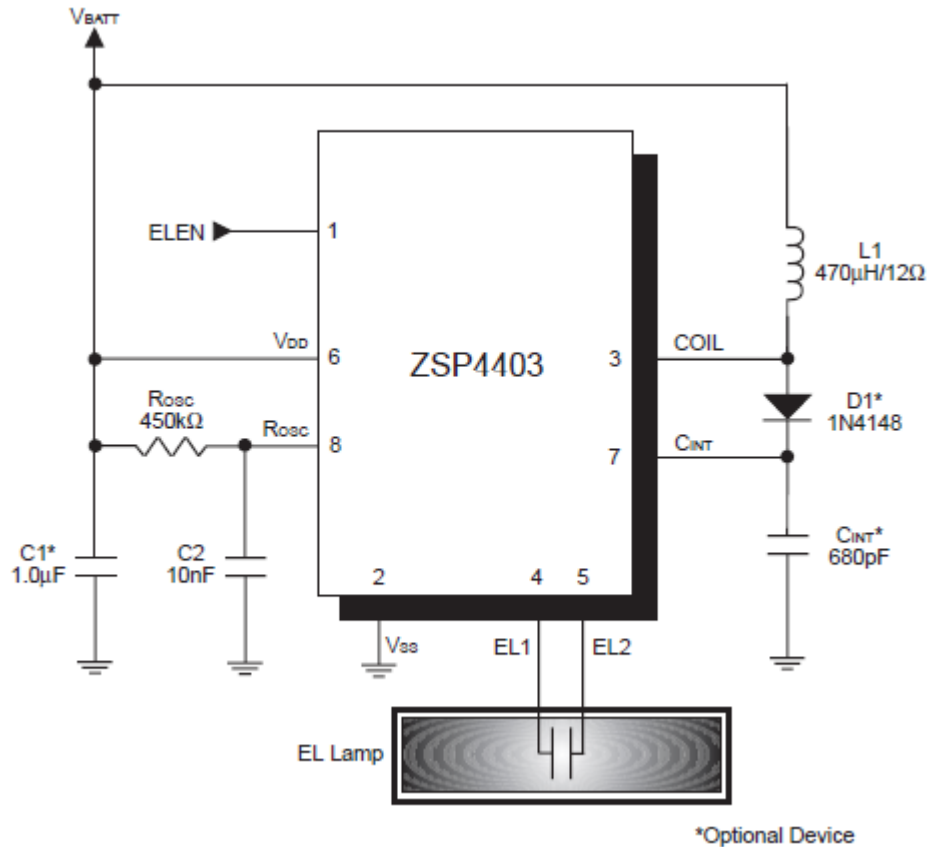

Figure 2. Typical Application Circuit, Set for a Square Wave Output with  $C_{INT} = 0.1\mu\text{F}$

## 8 Waveforms

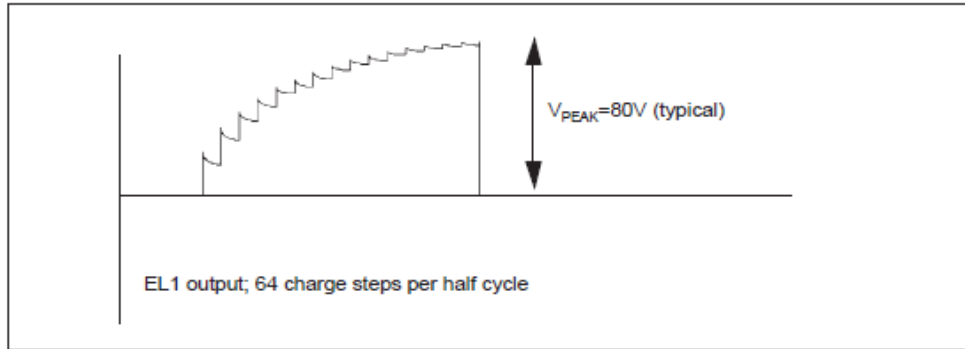

Figure 3. EL Output Voltage in Discrete Steps at EL1 Output

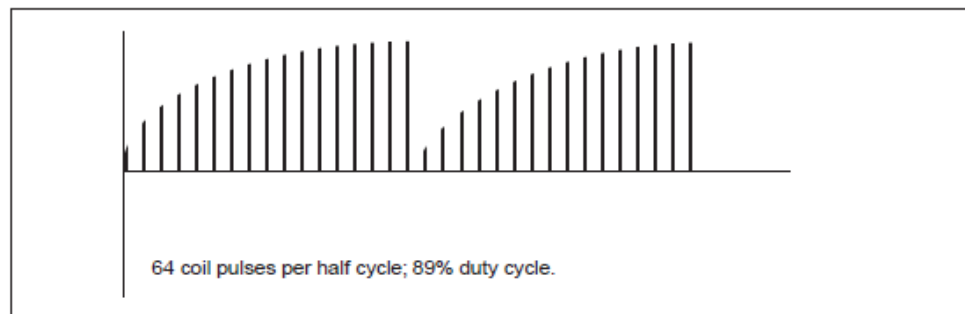

Figure 4. Voltage Pulses Released from the Coil to the EL Driver Circuitry

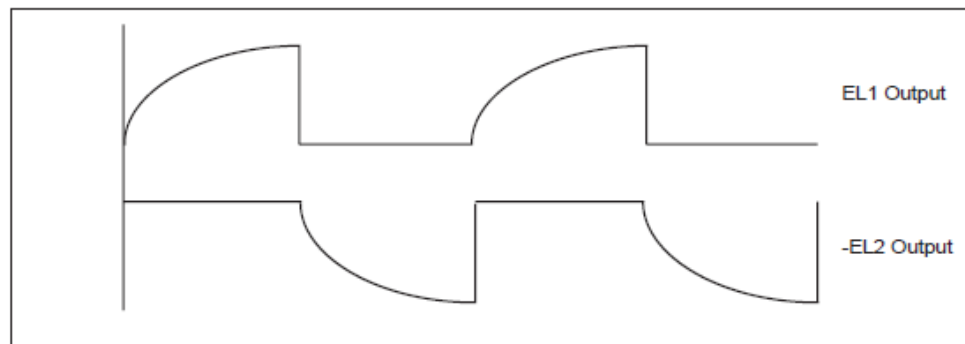

Figure 5. EL Voltage Waveforms from the EL1 and EL2 Outputs

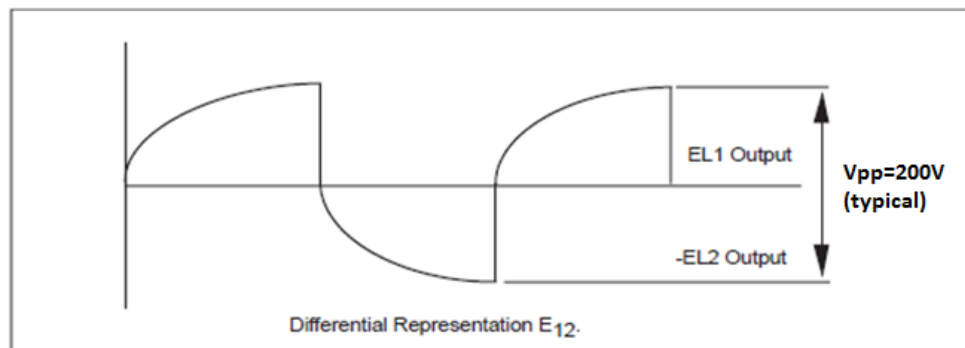
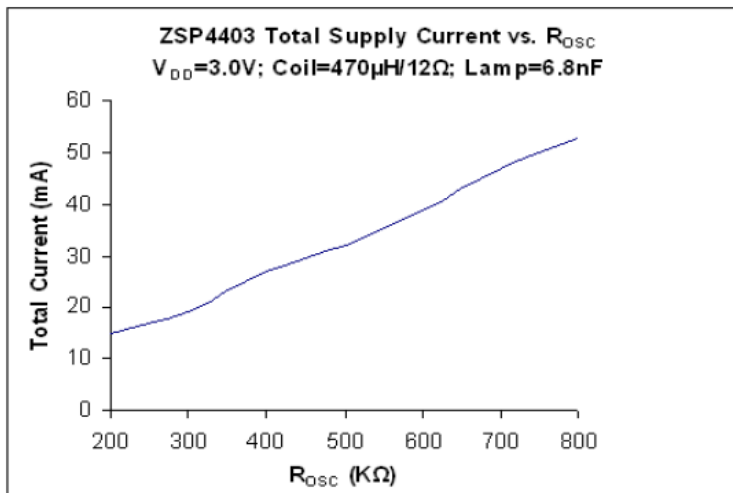
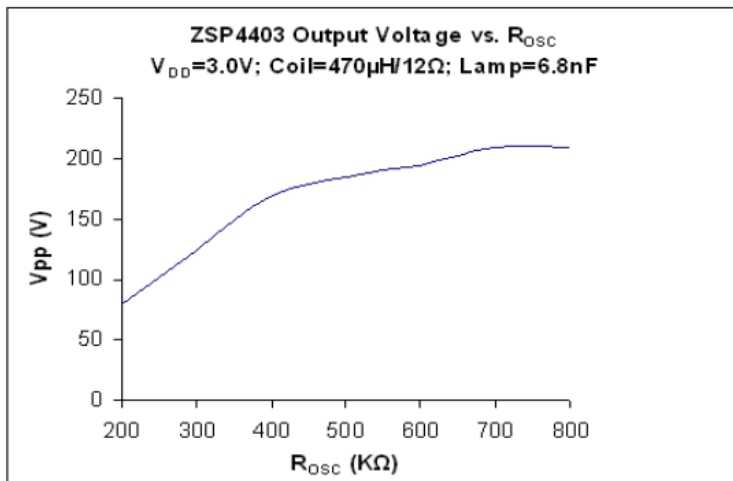
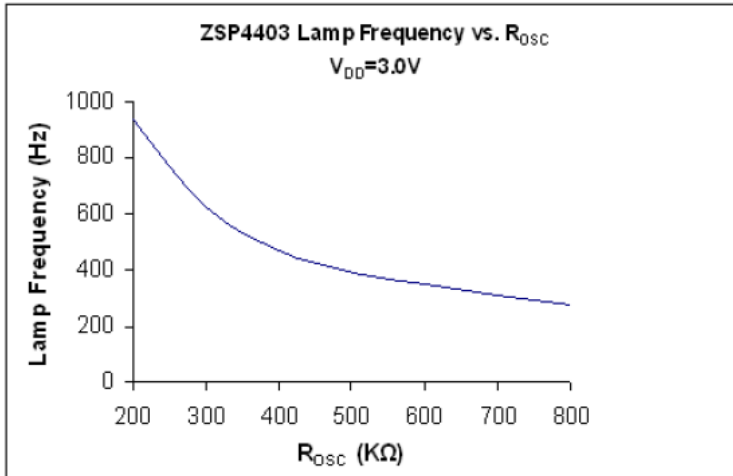

Figure 6. EL Differential Output Waveform of the EL1 and EL2 Outputs

## 9 Typical Performance Characteristics



**10 Manufacturers****Coil Manufacturers****Hitachi Metals**

Material Trading Division  
2101 S. Arlington Heights Road,  
Suite 116  
Arlington Heights, IL 60005-4142  
Phone: 1-800-777-8343 Ext. 12  
(847) 364-7200 Ext. 12  
Fax: (847) 364-7279

**Hitachi Metals Ltd. Europe**

Immernannstrasse 14-16, 40210  
Dusseldorf, Germany  
Contact: Gary Loos  
Phone: 49-211-16009-0  
Fax: 49-211-16009-29

**Hitachi Metals Ltd.**

Kishimoto Bldg. 2-1, Marunouchi  
2-chome, Chiyoda-Ku, Tokyo,  
Japan  
Contact: Mr. Noboru Abe  
Phone: 3-3284-4936  
Fax: 3-3287-1945

**Hitachi Metals Ltd. Singapore**

78 Shenton Way #12-01,  
Singapore 079120  
Contact: Mr. Stan Kaiko  
Phone: 222-8077  
Fax: 222-5232

**Hitachi Metals Ltd. Hong Kong**

Room 1107, 11/F., West Wing,  
Tsim Sha. Tsui Center 66  
Mody Road, Tsimshatsui East,  
Kowloon, Hong Kong  
Phone: 2724-4188  
Fax: 2311-2095

**Murata**

2200 Lake Park Drive, Smyrna  
Georgia 30080 U.S.A.  
Phone: (770) 436-1300  
Fax: (770) 436-3030

**Murata European**

Holbeinstrasse 21-23, 90441  
Numberg, Postfachanschrift 90015  
Phone: 011-4991166870  
Fax: 011-49116687225

**Murata Taiwan Electronics**

225 Chung-Chin Road, Taichung,  
Taiwan, R.O.C.  
Phone: 011 88642914151  
Fax: 011 88644252929

**Murata Electronics Singapore**

200 Yishun Ave. 7, Singapore  
2776, Republic of Singapore  
Phone: 011 657584233  
Fax: 011 657536181

**Murata Hong Kong**

Room 709-712 Miramar Tower, 1  
Kimberly Road, Tsimshatsui,  
Kowloon, Hong Kong  
Phone: 011-85223763898  
Fax: 011-85223755655

**Panasonic.**

6550 Katella Ave  
Cypress, CA 90630-5102  
Phone: (714) 373-7366  
Fax: (714) 373-7323

**Sumida Electric Co., LTD.**

5999, New Wilke Road,  
Suite #110  
Rolling Meadows, IL, 60008 U.S.A.  
Phone: (847) 956-0666  
Fax: (847) 956-0702

**Sumida Electric Co., LTD.**

4-8, Kanamachi 2-Chrome,  
Katsushika-ku, Tokyo 125 Japan  
Phone: 03-3607-5111  
Fax: 03-3607-5144

**Sumida Electric Co., LTD.**

Block 15, 996, Bendemeer Road  
#04-05 to 06, Singapore 339944  
Republic of Singapore  
Phone: 2963388  
Fax: 2963390

**Sumida Electric Co., LTD.**

14 Floor, Eastern Center, 1065  
King's Road, Quarry Bay,  
Hong Kong  
Phone: 28806688  
Fax: 25659600

**Polarizers/Transflector  
Manufacturers****Nitto Denko**

Yoshi Shinozuka  
Bayside Business Park 48500  
Fremont, CA. 94538  
Phone: 510 445 5400  
Fax: 510 445-5480

Top Polarizer- NPF F1205DU  
Bottom - NPF F4225  
or (F4205) P3 w/transflector

**Transflector Material**

Astra Products  
Mark Bogin  
P.O. Box 479  
Baldwin, NJ 11510  
Phone (516)-223-7500  
Fax (516)-868-2371

**EL Lamp Manufacturers****Leading Edge Ind. Inc.**

11578 Encore Circle  
Minnetonka, MN 55343  
Phone 1-800-845-6992

**Midori Mark Ltd.**

1-5 Komagata 2-Chome  
Taita-Ku 111-0043 Japan  
Phone: 81-03-3848-2011

**NEC Corporation**

Yumi Saskai  
7-1, Shiba 5 Chome, Minato-ku,  
Tokyo 108-01, Japan  
Phone: (03) 3798-9572  
Fax: (03) 3798-6134

**Seiko Precision**

Shuzo Abe  
1-1, Taihei 4-Chome,  
Sumida-ku, Tokyo, 139 Japan  
Phone: (03) 5610-7089  
Fax: (03) 5610-7177

**Gunze Electronics**

2113 Wells Branch Parkway  
Austin, TX 78728  
Phone: (512) 752-1299  
Fax: (512) 252-1181

## 11 Ordering Information

Part Number	Temperature Range	Package Type	Green Package
ZSP4403EU	-40°C to +85°C	8-pin MSOP	N/A
ZSP4403LEU	-40°C to +85°C	8-pin MSOP Green	
ZSP4403UEB	N/A	Evaluation Board	N/A

Please contact the factory for pricing and availability on Tape-on-Reel options.

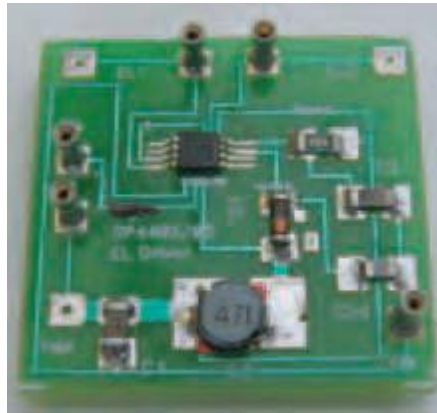

Please contact the factory for EL driver design support and availability of custom-made evaluation demo boards. See our web site for AN007 Application Note regarding requirements for custom-made evaluation demo boards.

## 12 Package Information

All package dimensions in inches

### 8-pin MSOP

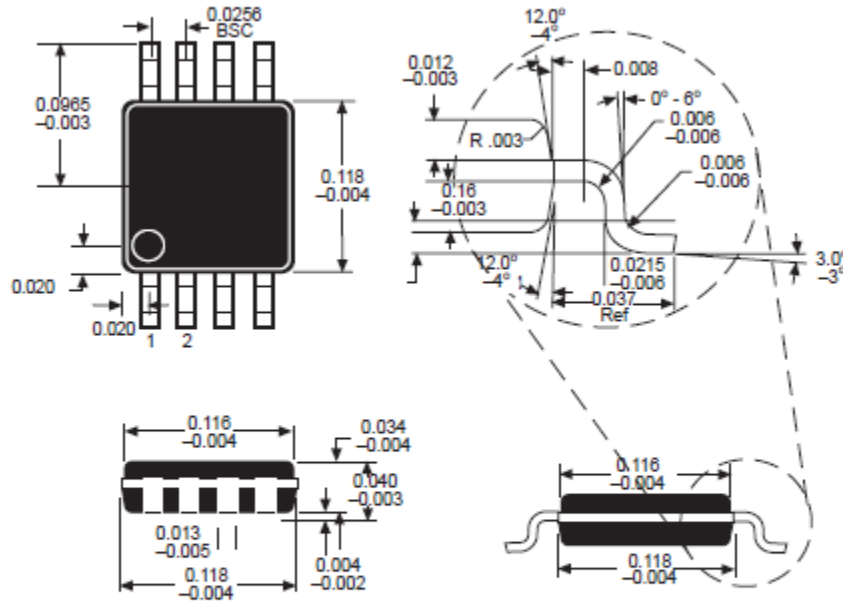

50 ZSP4403EU devices per tube

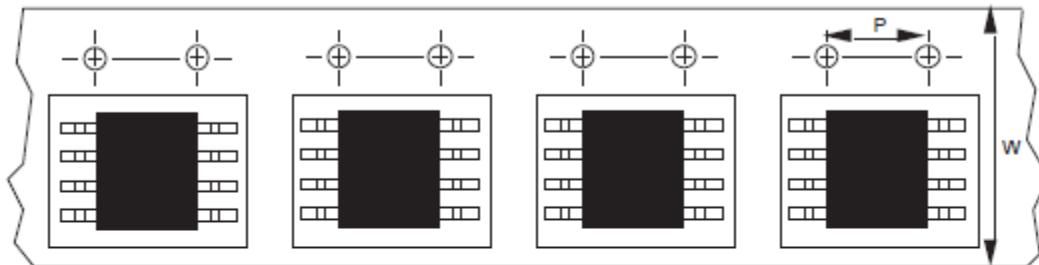

MSOP-8 13" reels: P=8mm, W=12mm

Package	Minimum qty per reel	Standard qty per reel	Maximum qty per reel
EU	500	2500	3000





## Revision History

Revision	Date	Comment
V0.2	2005/01/01	Initial release to customers
V2.00	2015/06/03	<ol style="list-style-type: none"><li>1. Changed to ASIX Electronics Corp. logo, strings and contact information.</li><li>2. Added ASIX copyright legal header information.</li><li>3. Modified the Revision History table format.</li><li>4. Modified some Vpp descriptions.</li></ol>
V2.01	2019/05/29	Added some description in Section 3



**ZSP4403**  
**Low Voltage Electroluminescent Lamp Driver**  
**High Voltage Output for Large Display**

---



4F, No. 8, Hsin Ann Rd., HsinChu Science Park,  
HsinChu, Taiwan, R.O.C.

TEL: 886-3-5799500

FAX: 886-3-5799558

Sales Email: [sales@asix.com.tw](mailto:sales@asix.com.tw)

Support Email: [support@asix.com.tw](mailto:support@asix.com.tw)

Web: <http://www.asix.com.tw>